

NATIONAL INTREPID CENTER OF EXCELLENCE (NICoE)

National Naval Medical Center | Bethesda, MD



Schematic Design Proposal | Christine Clowes | December 11, 2008

BUILDING OVERVIEW

NATIONAL INTREPID
CENTER OF EXCELLENCE

Location

National Naval Medical Center,
Bethesda, MD

Construction Period

June 2008 – October 2009

Size

72,000 sq. ft.

Design Team

Owner: Plaza Construction

Construction Manager: Turner Construction

Architect: SmithGroup

Structural Engineer: Cagley & Associates

MEP Engineer: SmithGroup

Lighting Designer: SmithGroup

Budget

\$65 million



BUILDING OVERVIEW

NATIONAL INTREPID
CENTER OF EXCELLENCE

- Research, diagnosis, and treatment of military personnel and veterans
 - Traumatic brain injuries (TBI)
 - Psychological issues
- Group and family treatment rooms
- Landscaped exterior spaces and playgrounds

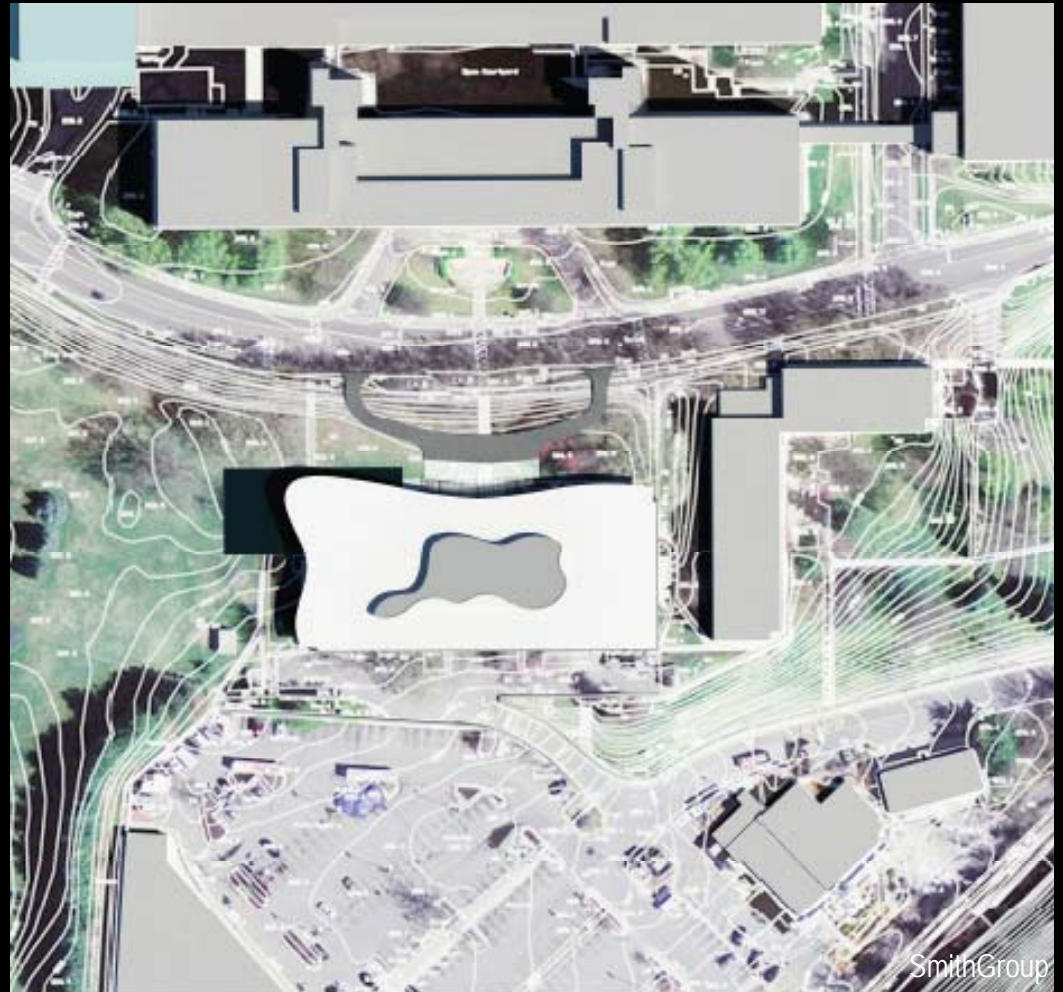

BUILDING OVERVIEW

NATIONAL INTREPID
CENTER OF EXCELLENCE

"Bar" Section

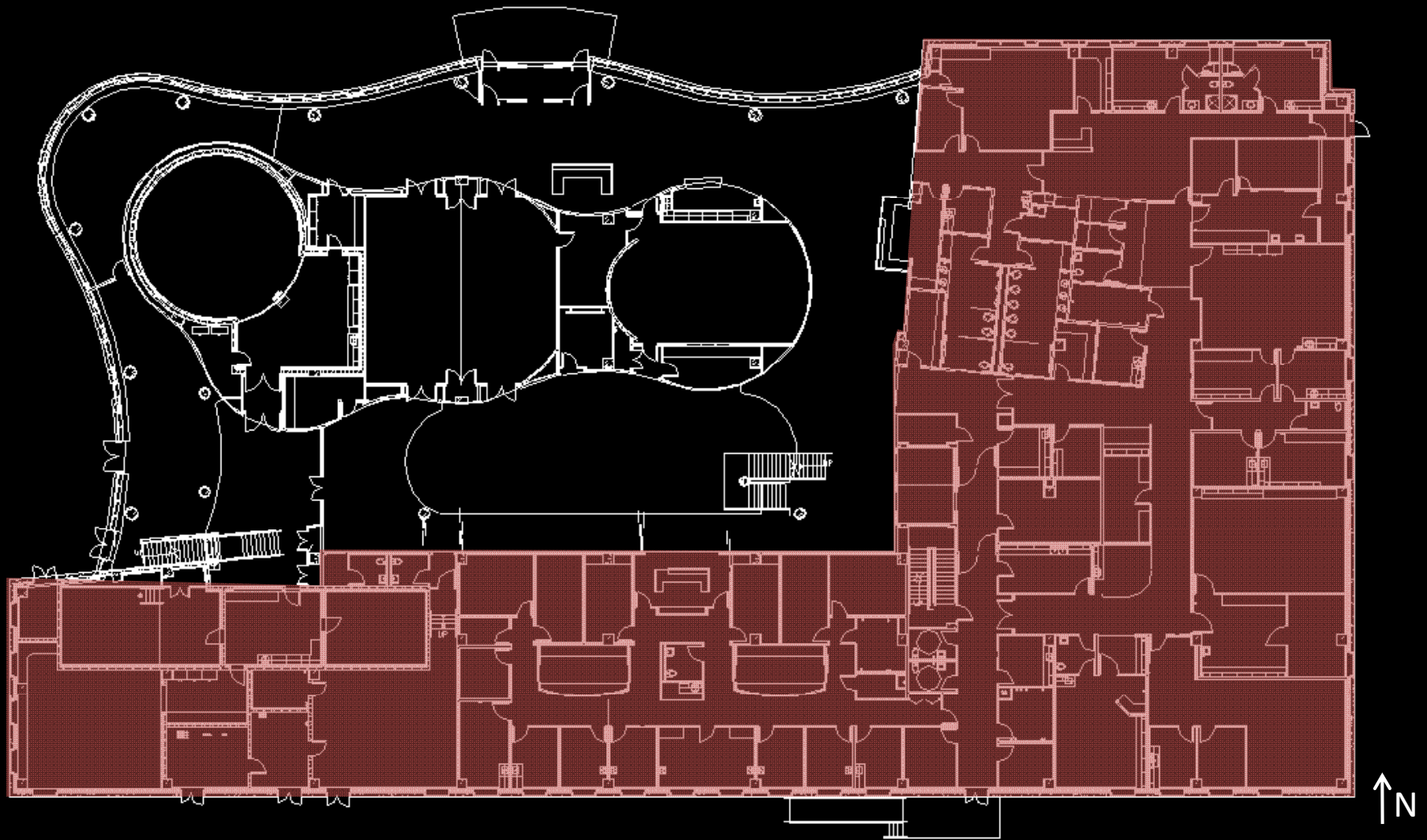

BUILDING OVERVIEW

NATIONAL INTREPID
CENTER OF EXCELLENCE

"Amorphous" Section

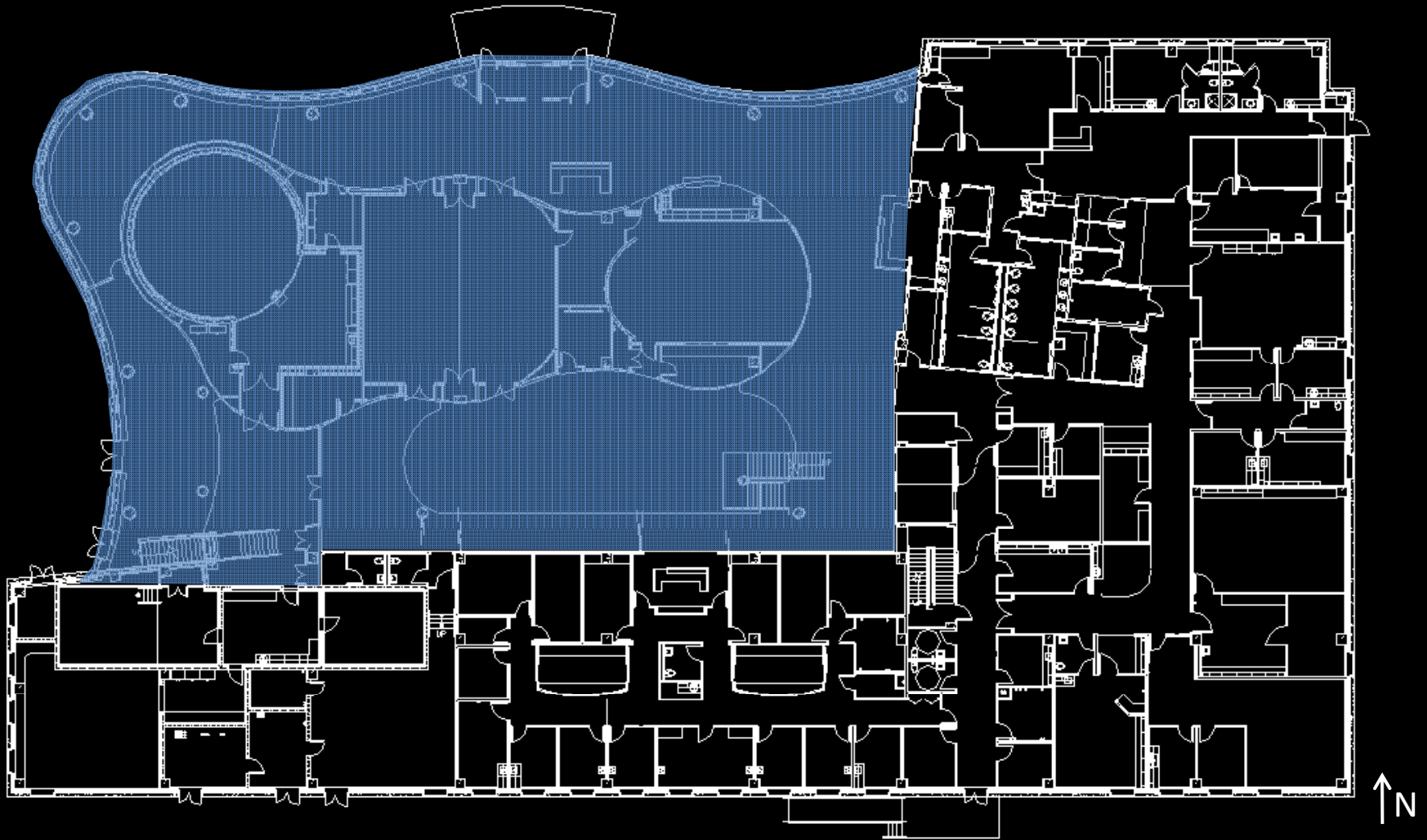

DESIGN CONCEPT & GOALS

NATIONAL INTREPID
CENTER OF EXCELLENCE

Concept

- Characteristics/Qualities of a Soldier

Goals

- Portray strength, focus, unity, and leadership
- Calm, comfortable, and healing atmosphere
- Articulation of architectural features
- Integrate daylight
- Avoid:
 - High brightness
 - High contrast
 - Direct glare



EXTERIOR FAÇADE

NATIONAL INTREPID
CENTER OF EXCELLENCE

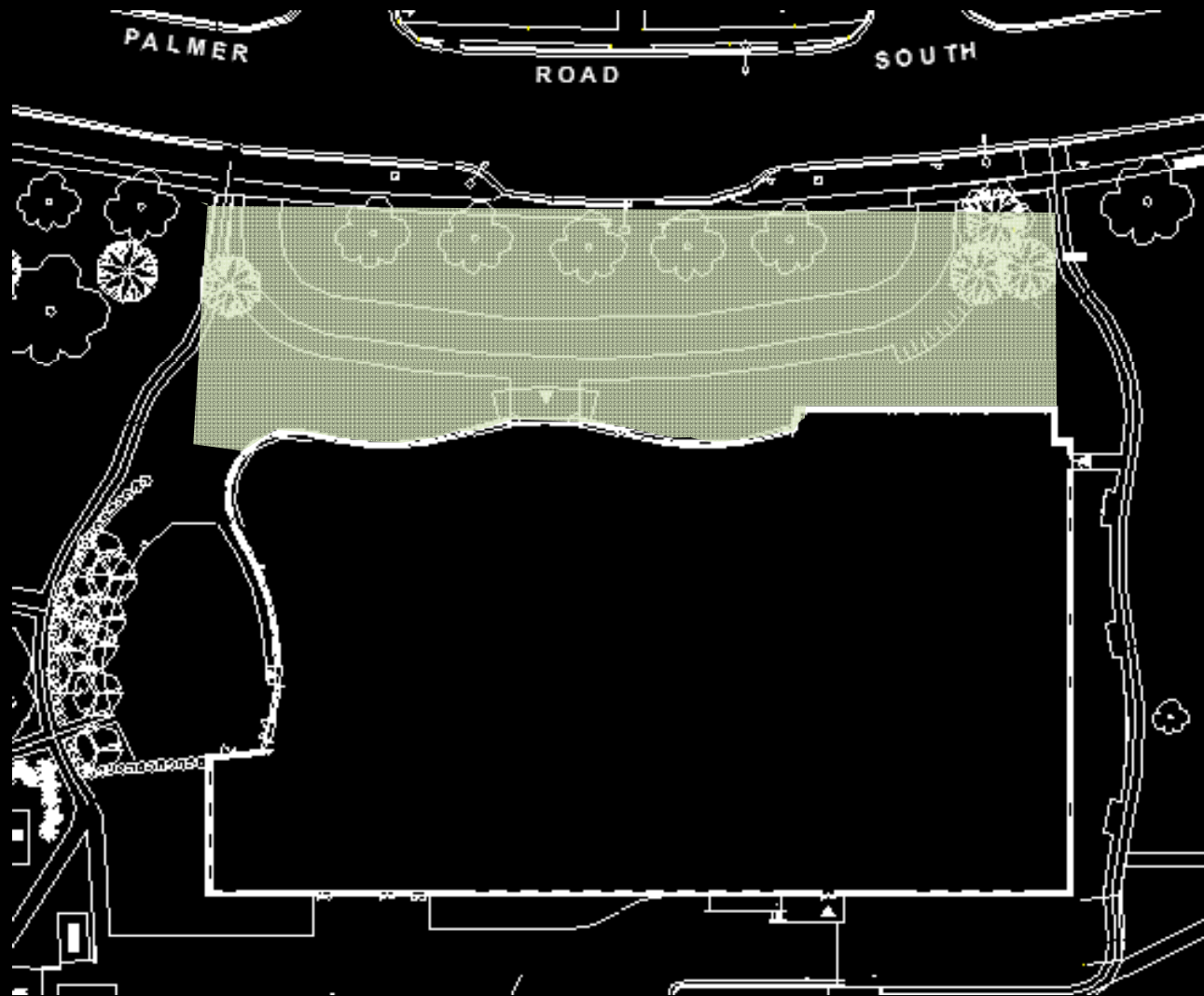

EXTERIOR FAÇADE | FEATURES

NATIONAL INTREPID
CENTER OF EXCELLENCE

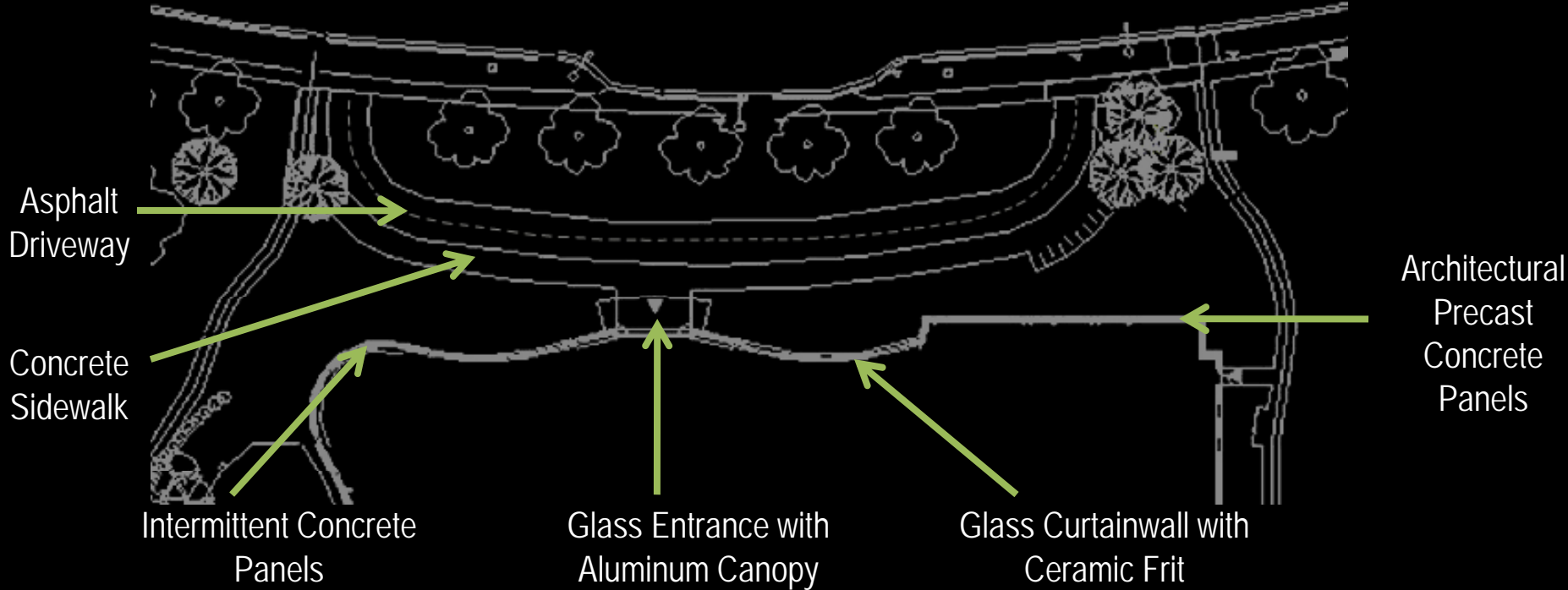

Concept

- Unity
- Teamwork

Criteria

- Uniform lighting on walkways
- Mid to high range CCT
- Highlight entrance canopy
- Accentuate building shape
- Visual Clarity
- Horizontal Illuminance
 - Walkways: 1 fc
 - Roadway: 0.3 to 0.6 fc
 - Entrance: 5 fc

EXTERIOR FAÇADE | SCHEMATIC DESIGN

NATIONAL INTREPID
CENTER OF EXCELLENCE

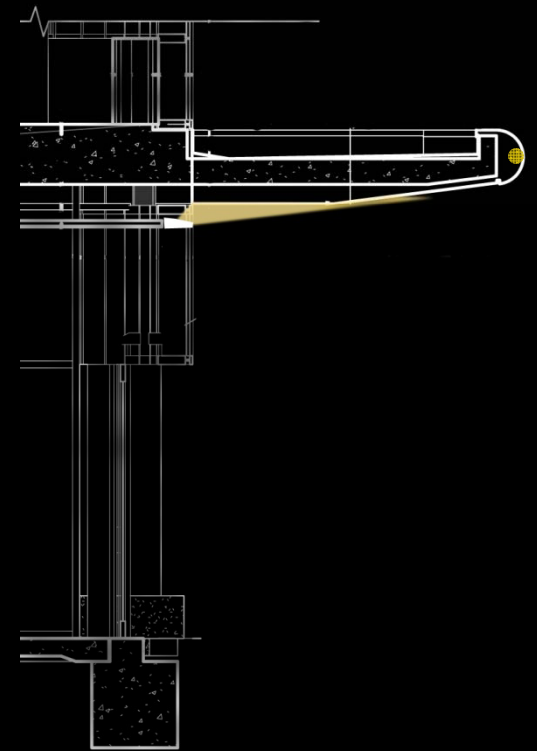

EXTERIOR FAÇADE | SCHEMATIC DESIGN 1

NATIONAL INTREPID
CENTER OF EXCELLENCE

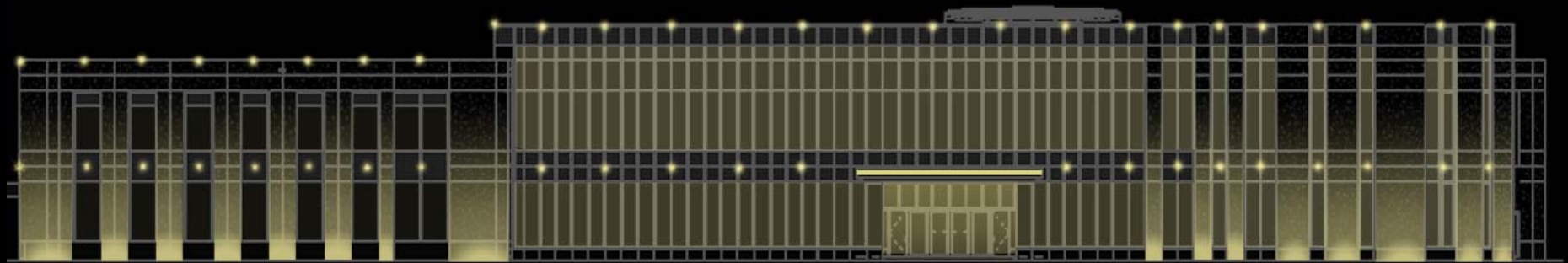

EXTERIOR FAÇADE | SCHEMATIC DESIGN 2

NATIONAL INTREPID
CENTER OF EXCELLENCE

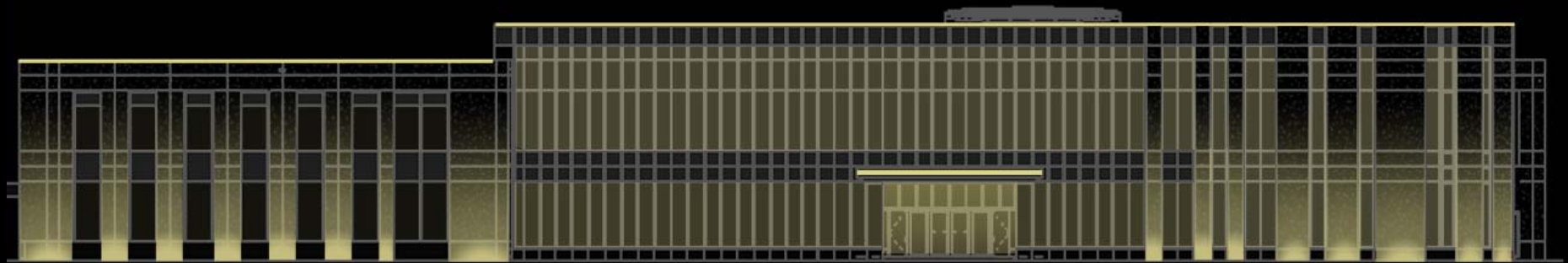

EXTERIOR FAÇADE | SCHEMATIC DESIGN 3

NATIONAL INTREPID
CENTER OF EXCELLENCE

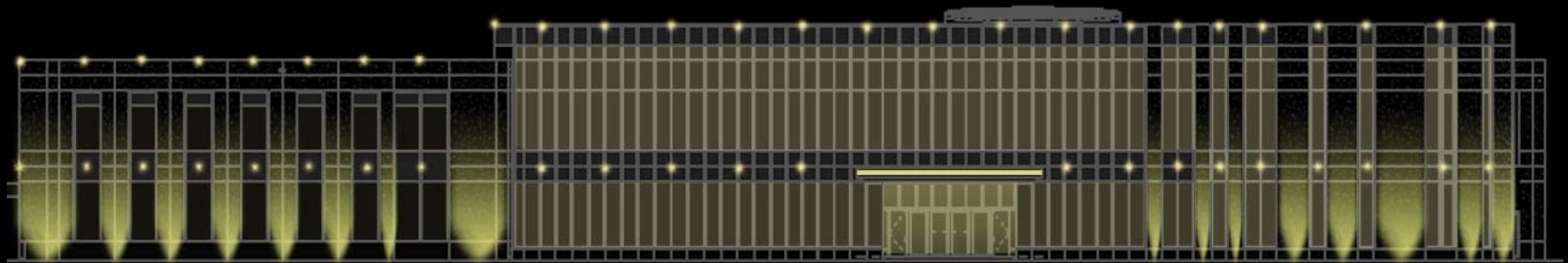

EXTERIOR FAÇADE | SCHEMATIC DESIGN 4

NATIONAL INTREPID
CENTER OF EXCELLENCE

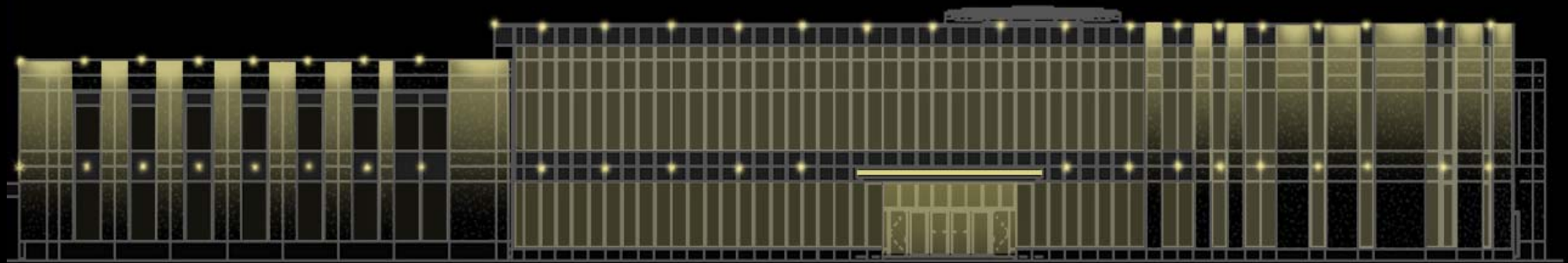

EXTERIOR FAÇADE | SCHEMATIC DESIGN 5

NATIONAL INTREPID
CENTER OF EXCELLENCE

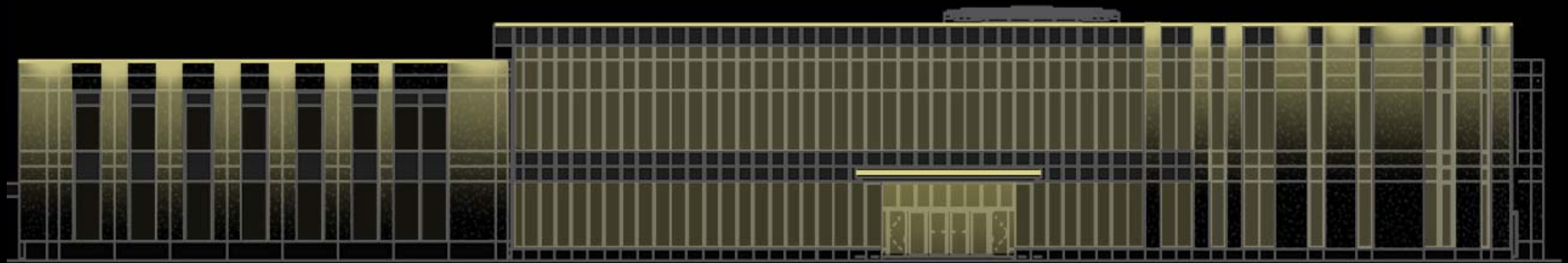

EXTERIOR SITE | SCHEMATIC DESIGN 1

NATIONAL INTREPID
CENTER OF EXCELLENCE



EXTERIOR SITE | SCHEMATIC DESIGN 2

NATIONAL INTREPID
CENTER OF EXCELLENCE

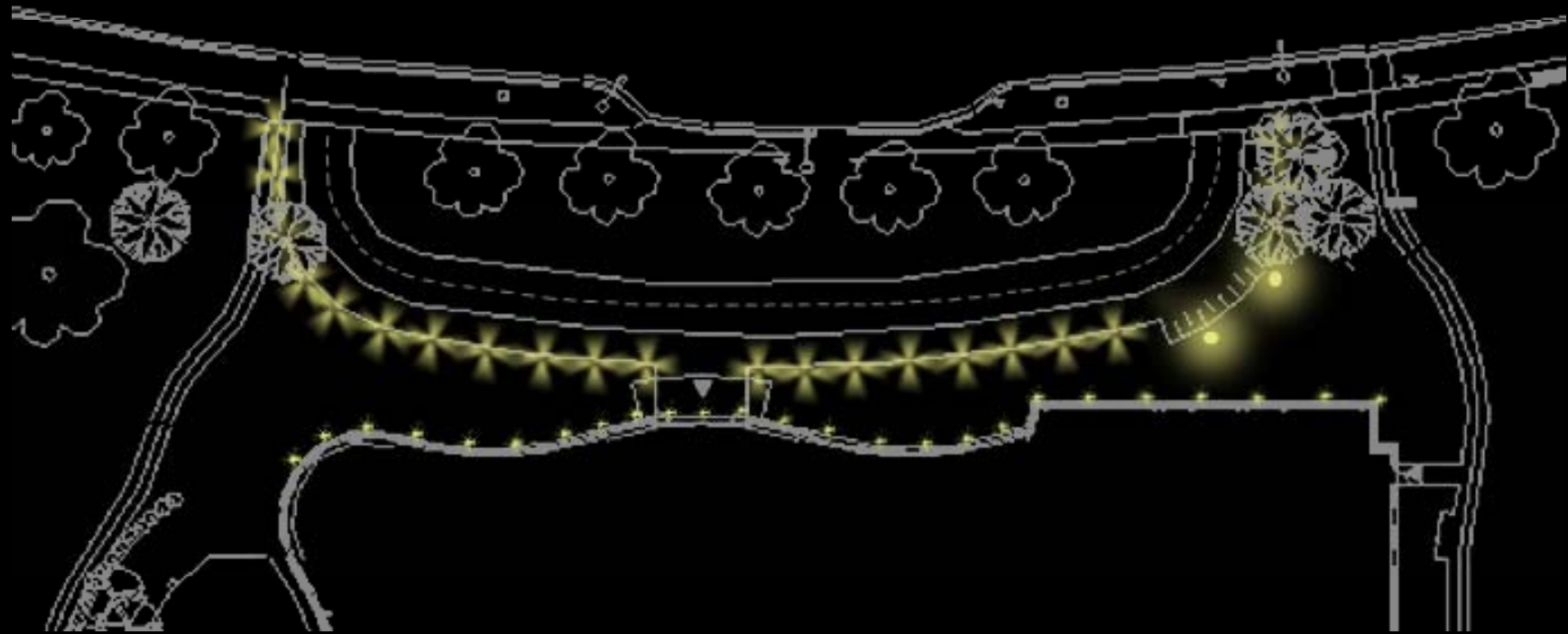

EXTERIOR SITE | SCHEMATIC DESIGN 3

NATIONAL INTREPID
CENTER OF EXCELLENCE

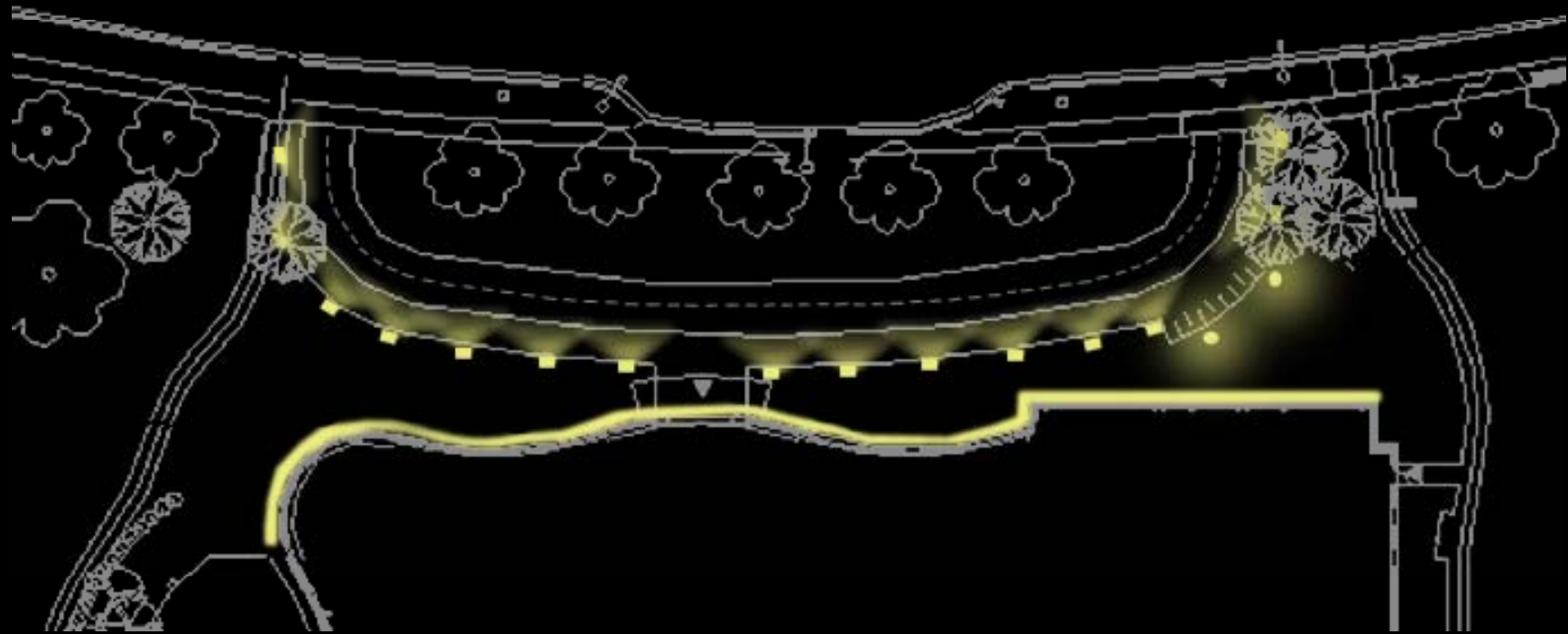

LOBBY

NATIONAL INTREPID
CENTER OF EXCELLENCE

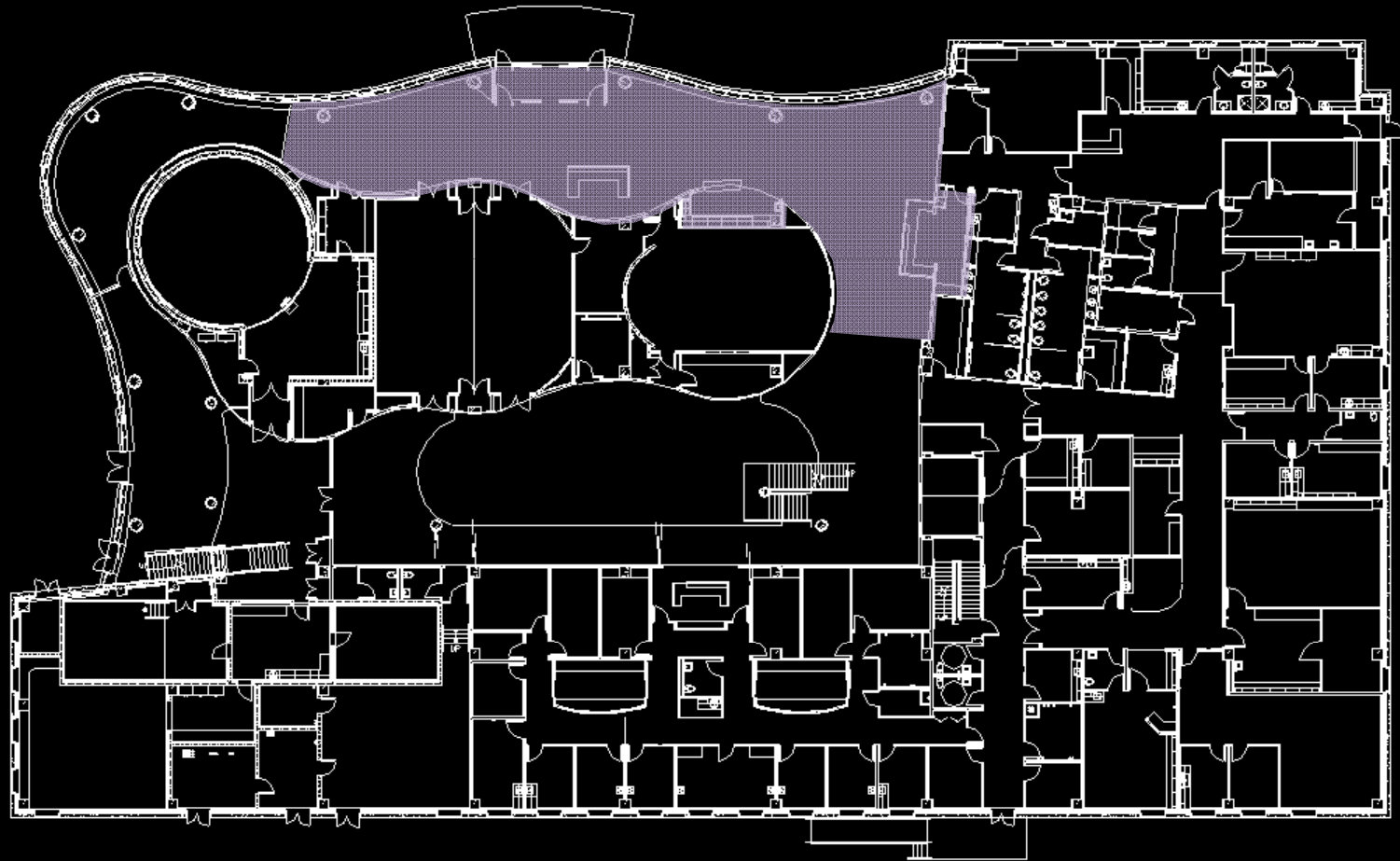

LOBBY

NATIONAL INTREPID
CENTER OF EXCELLENCE

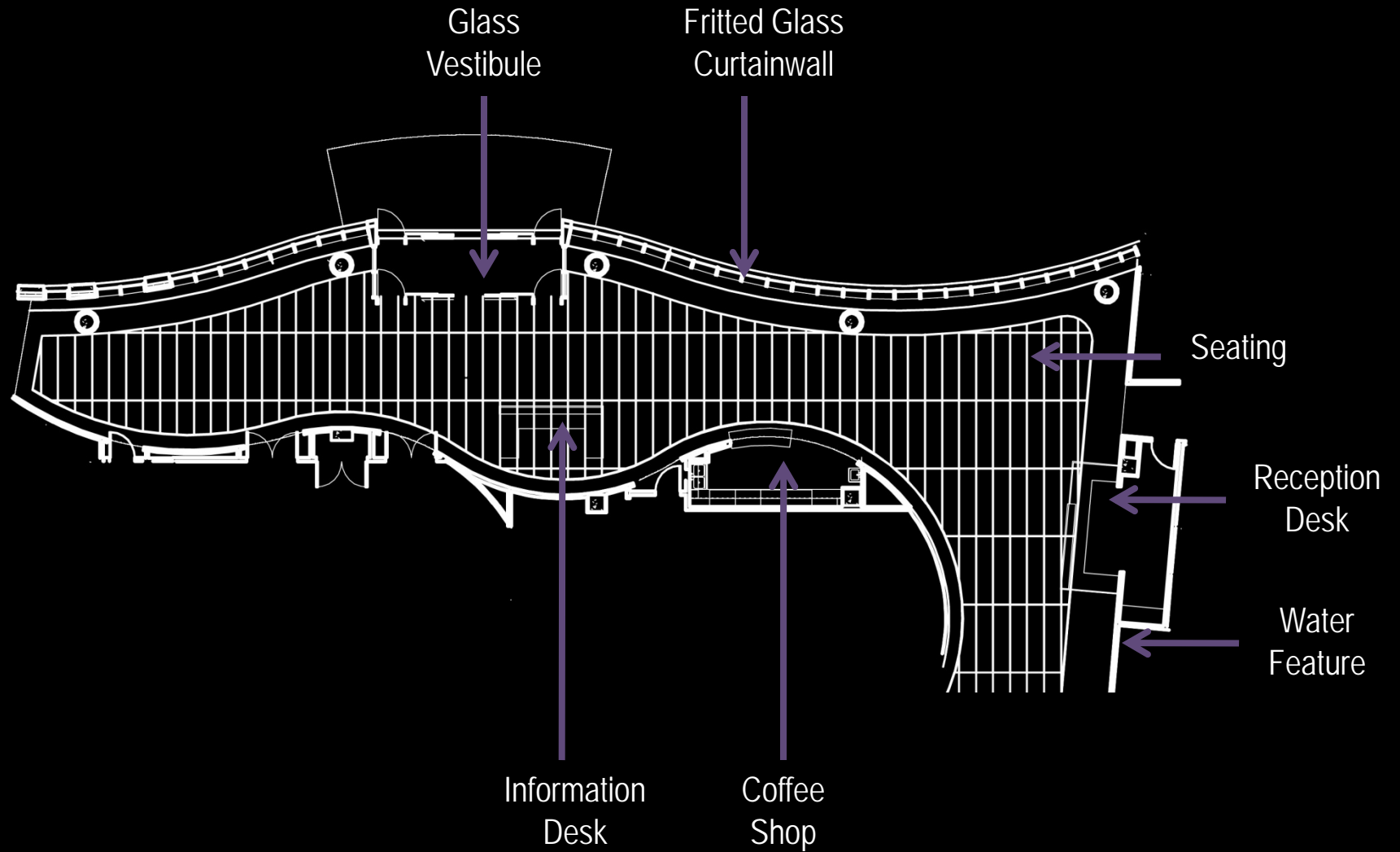

Concept

- Leadership
- Guidance

Criteria

- Promote circulation throughout space
- Some peripheral emphasis
- Mid range CCT
- Non-uniformity throughout entire space, but uniform on task planes
- Relaxation and pleasantness
- Horizontal Illuminance
 - Desk: 30 fc
 - Circulation space: 5 fc

LOBBY | SCHEMATIC DESIGN

NATIONAL INTREPID
CENTER OF EXCELLENCE

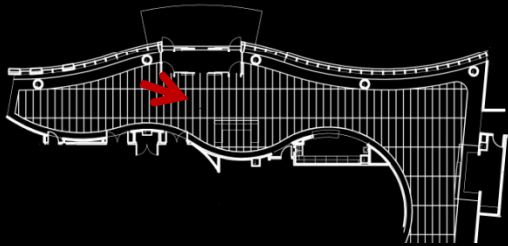

LOBBY | SCHEMATIC DESIGN

NATIONAL INTREPID
CENTER OF EXCELLENCE

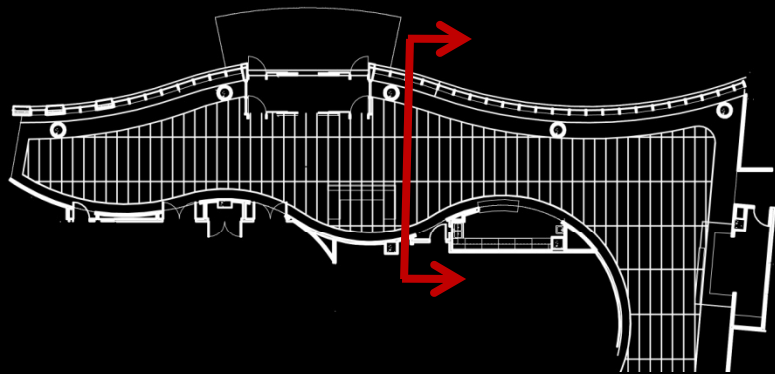
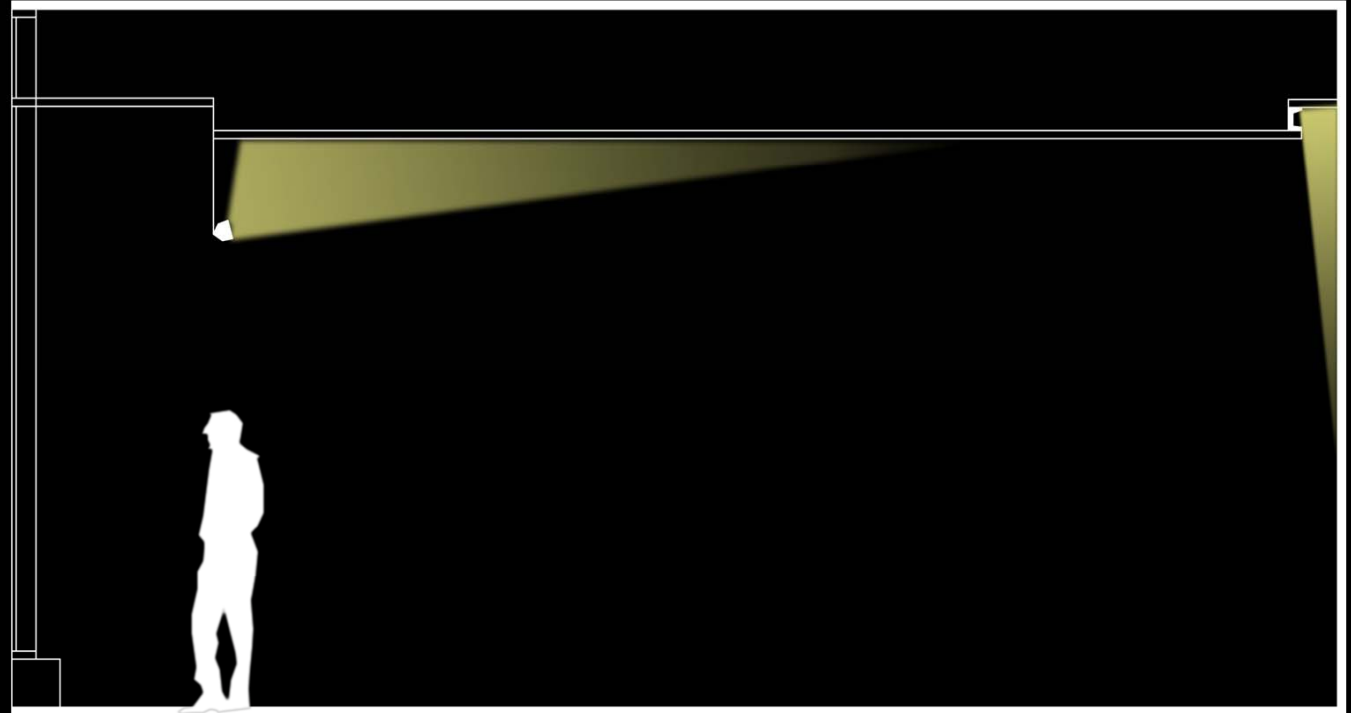

LOBBY | SCHEMATIC DESIGN

NATIONAL INTREPID
CENTER OF EXCELLENCE

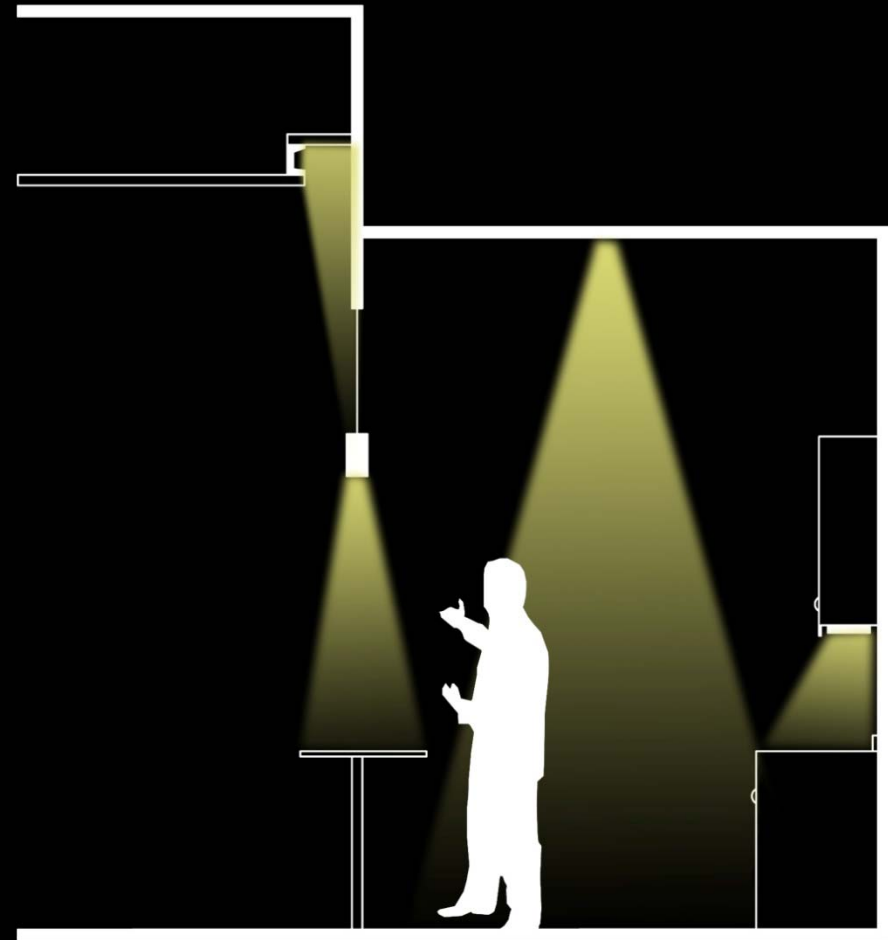
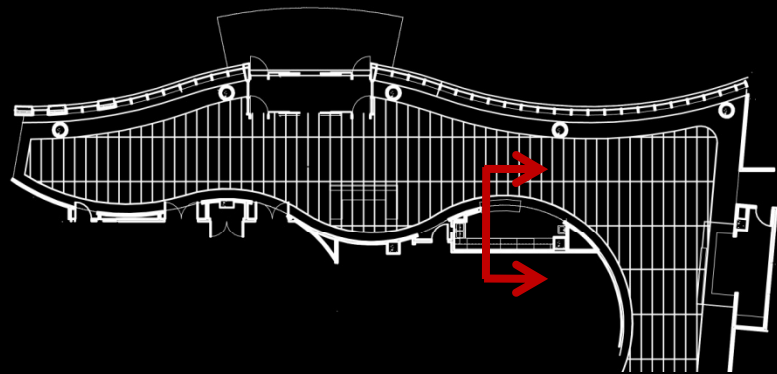

LOBBY | SCHEMATIC DESIGN

NATIONAL INTREPID
CENTER OF EXCELLENCE

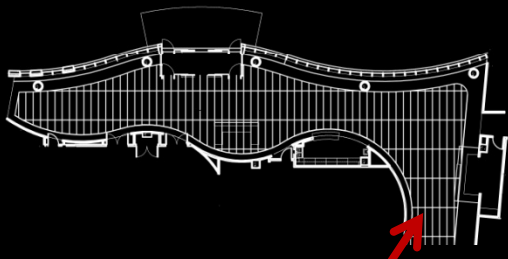
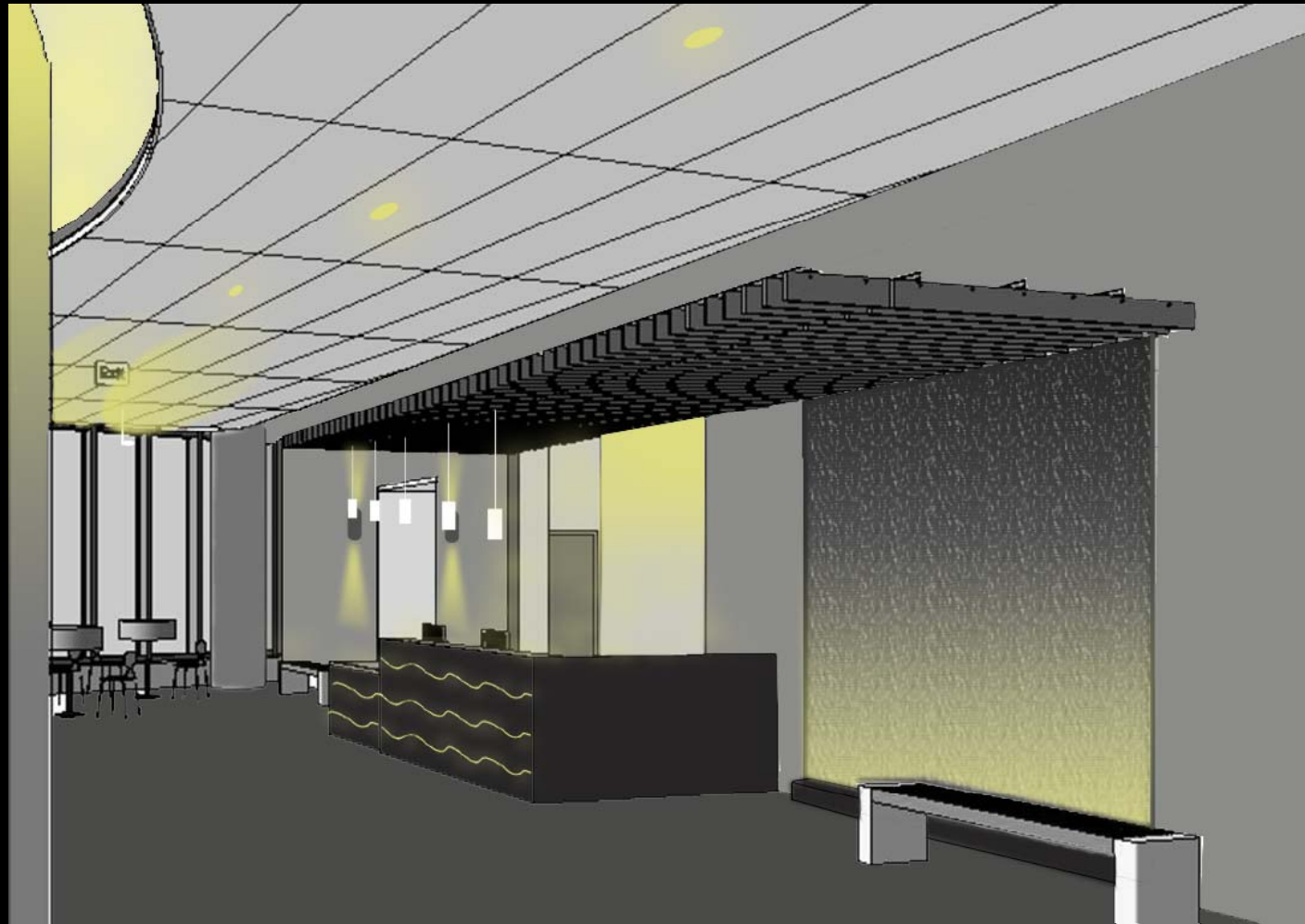

AUDITORIUM

NATIONAL INTREPID
CENTER OF EXCELLENCE

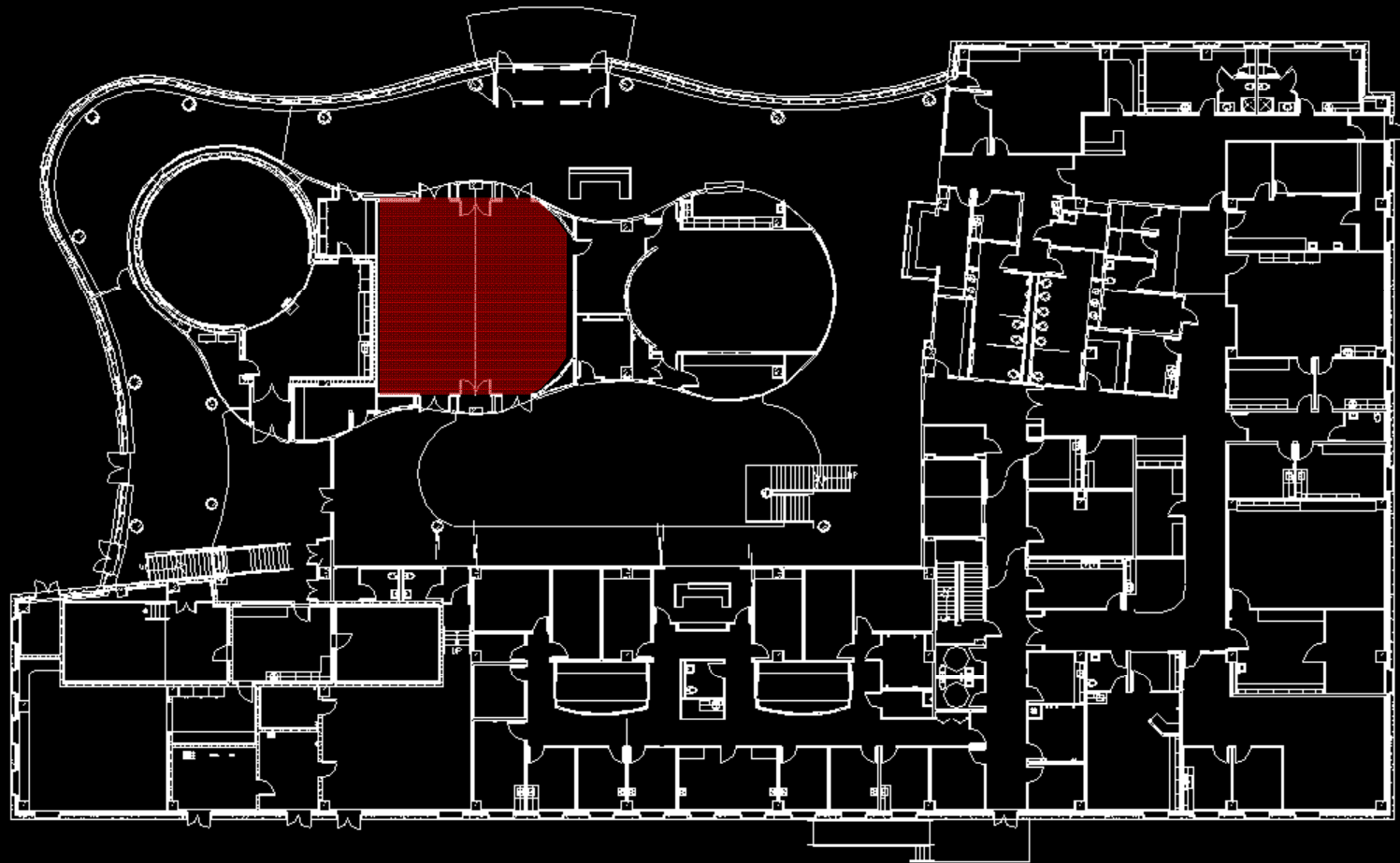

AUDITORIUM

NATIONAL INTREPID
CENTER OF EXCELLENCE

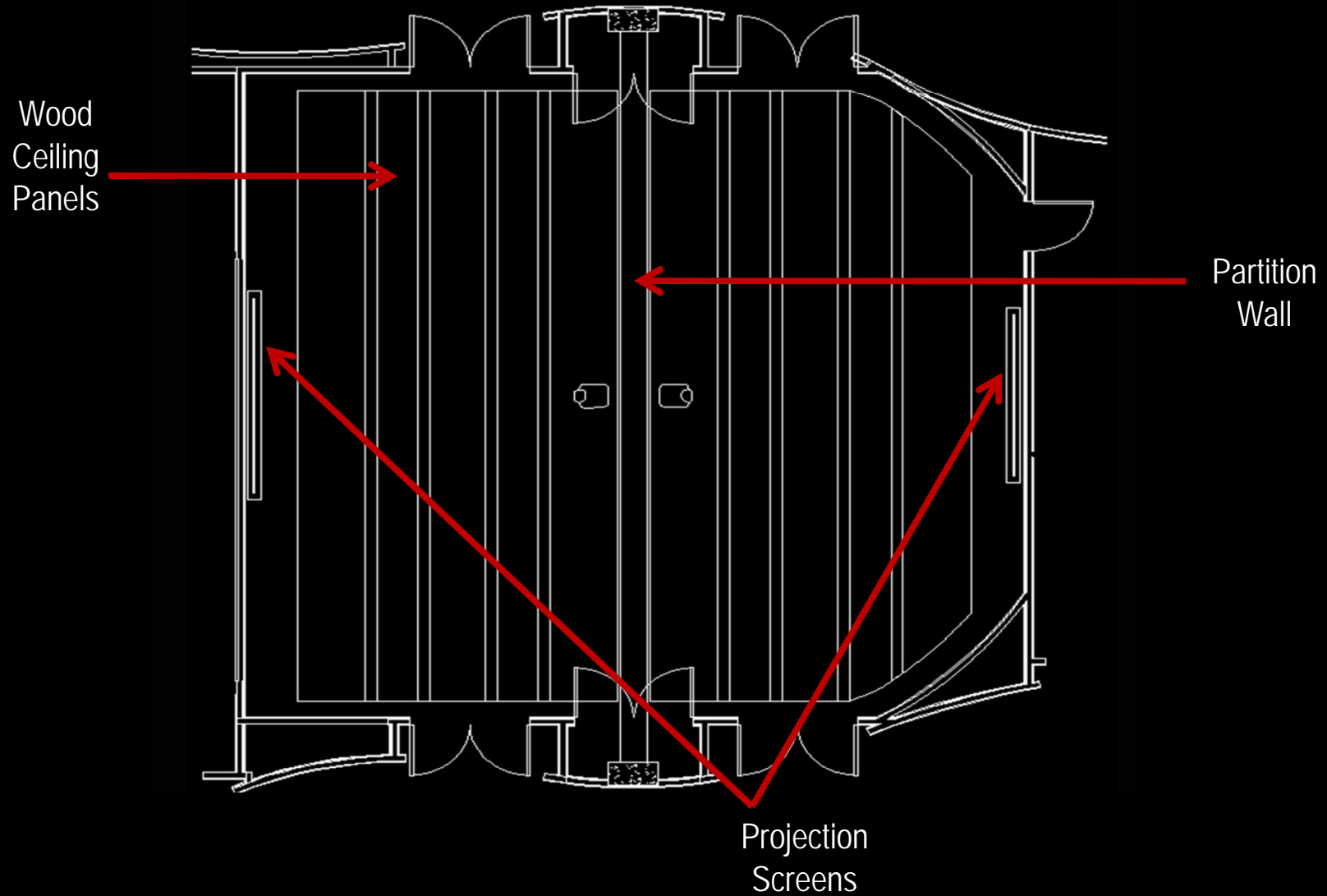

Concept

- Commitment
- Dedication
- Focus

Criteria

- Uniform lighting on task plane
- Low CCT
- Various scene controls
- Visual clarity
- Horizontal Illuminance
 - At 2.5 feet: 30 fc
- Vertical Illuminance
 - Projection screen: < 5 fc
 - Video teleconferencing: 30-50 fc

AUDITORIUM | SCHEMATIC DESIGN

NATIONAL INTREPID
CENTER OF EXCELLENCE

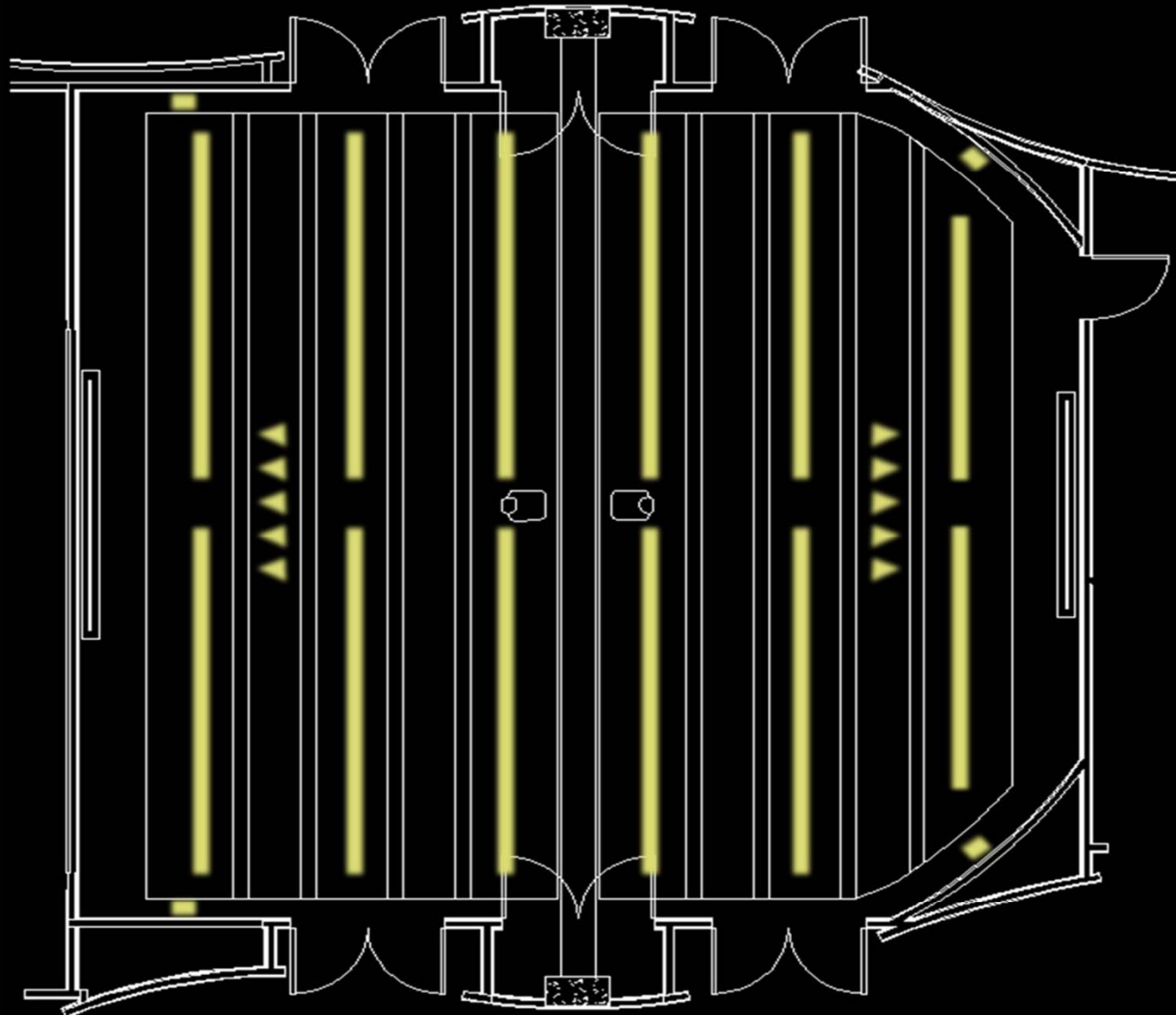

AUDITORIUM | SCHEMATIC DESIGN

NATIONAL INTREPID
CENTER OF EXCELLENCE

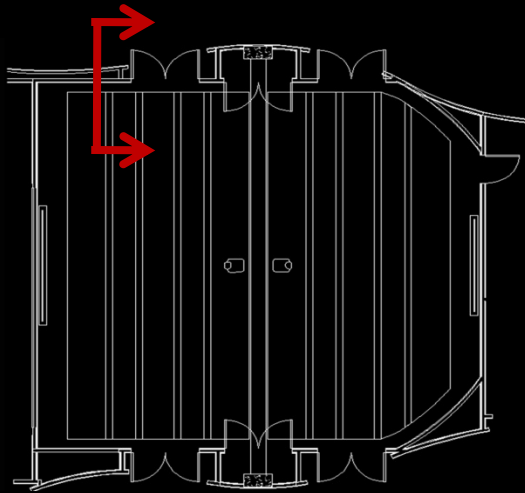

AUDITORIUM | SCHEMATIC DESIGN

NATIONAL INTREPID
CENTER OF EXCELLENCE

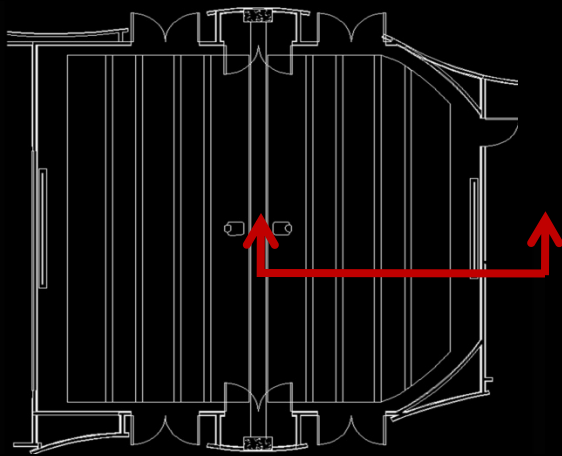
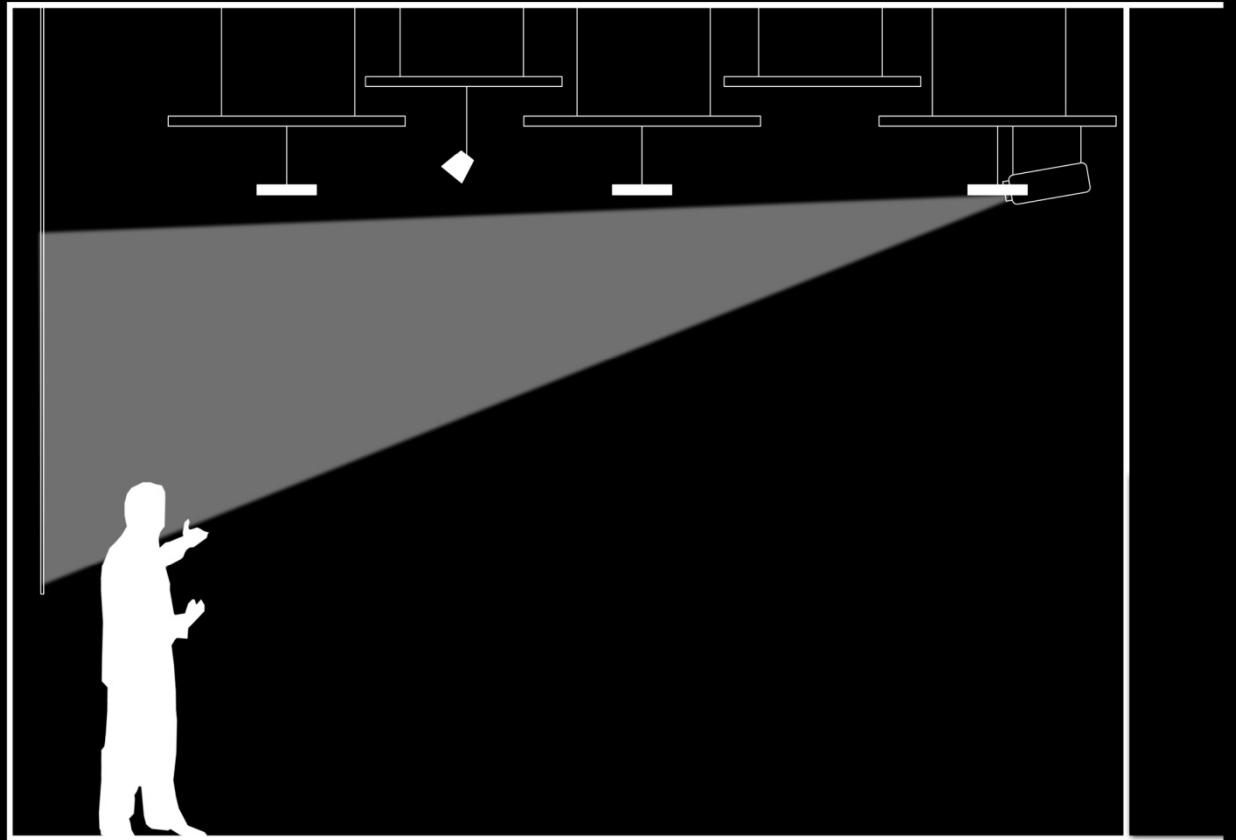

PT / OT

NATIONAL INTREPID
CENTER OF EXCELLENCE

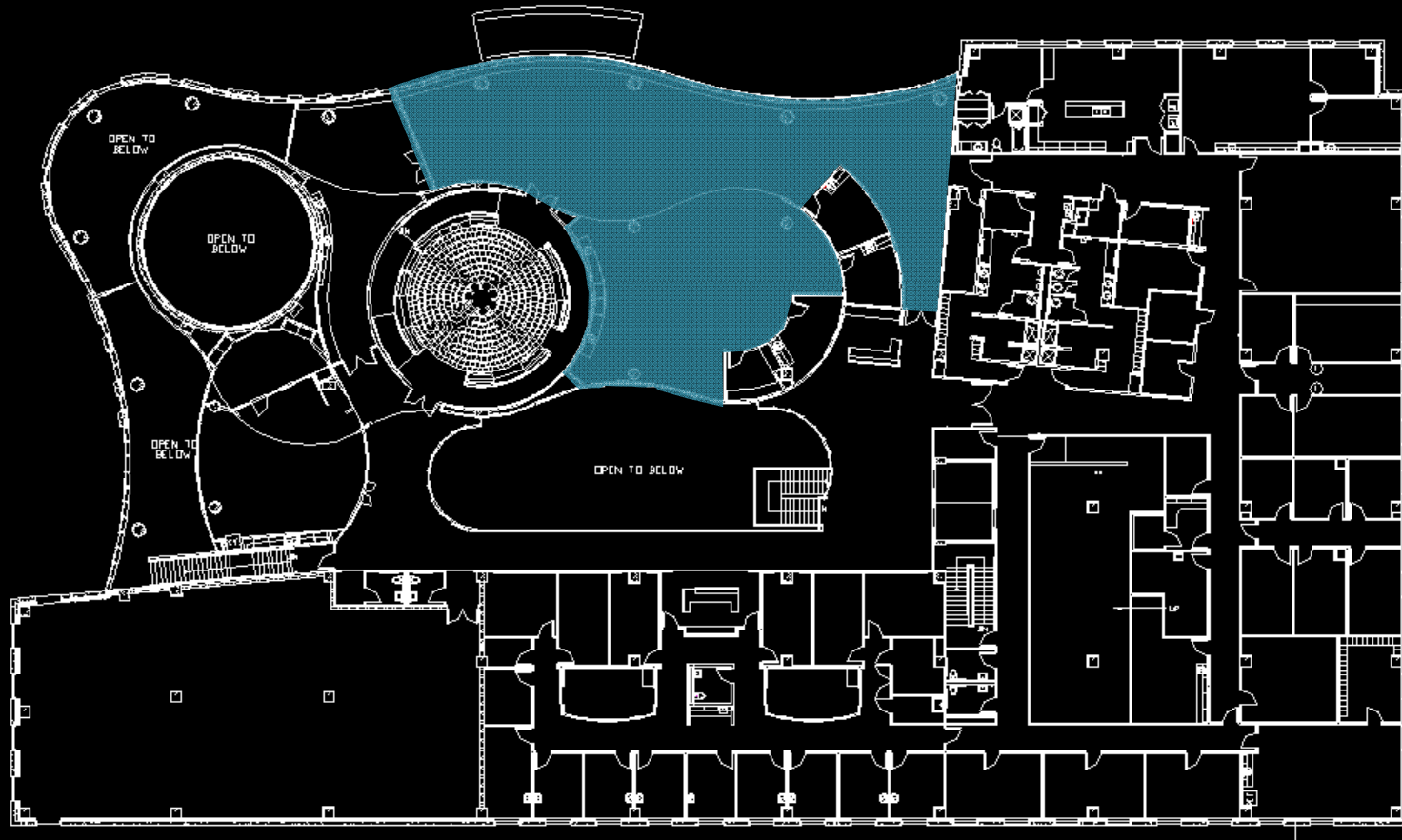

PT / OT

NATIONAL INTREPID
CENTER OF EXCELLENCE

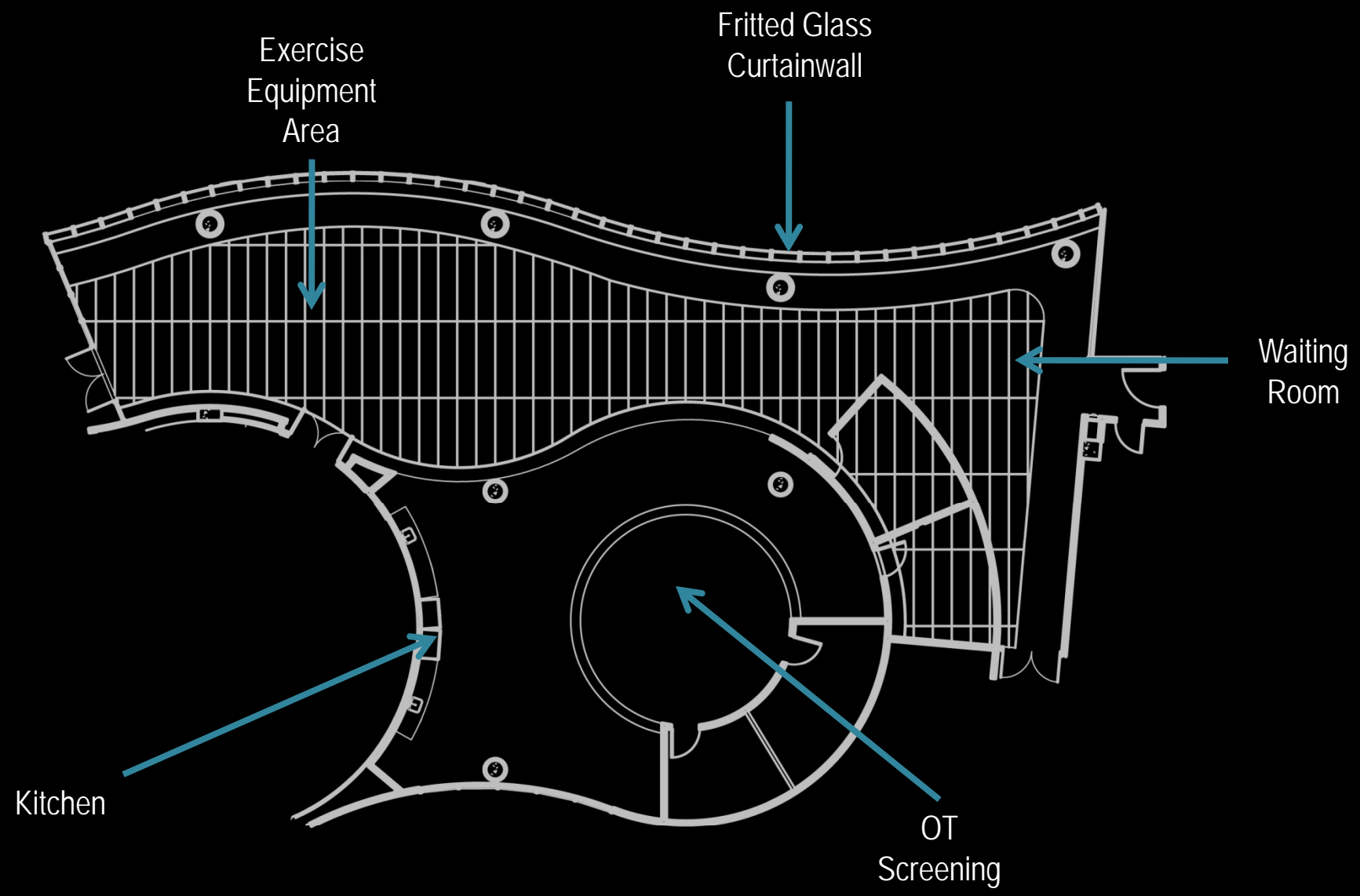

Concept

- Strength
- Structure

Criteria

- Uniform lighting in work areas with some peripheral emphasis
- Accentuate walls and structure
- Mid-range CCT
- Relaxation and visual clarity
- Horizontal Illuminance
 - Workplane: 30 fc
- Vertical Illuminance
 - Faces: 5 fc

PT / OT | SCHEMATIC DESIGN

NATIONAL INTREPID
CENTER OF EXCELLENCE

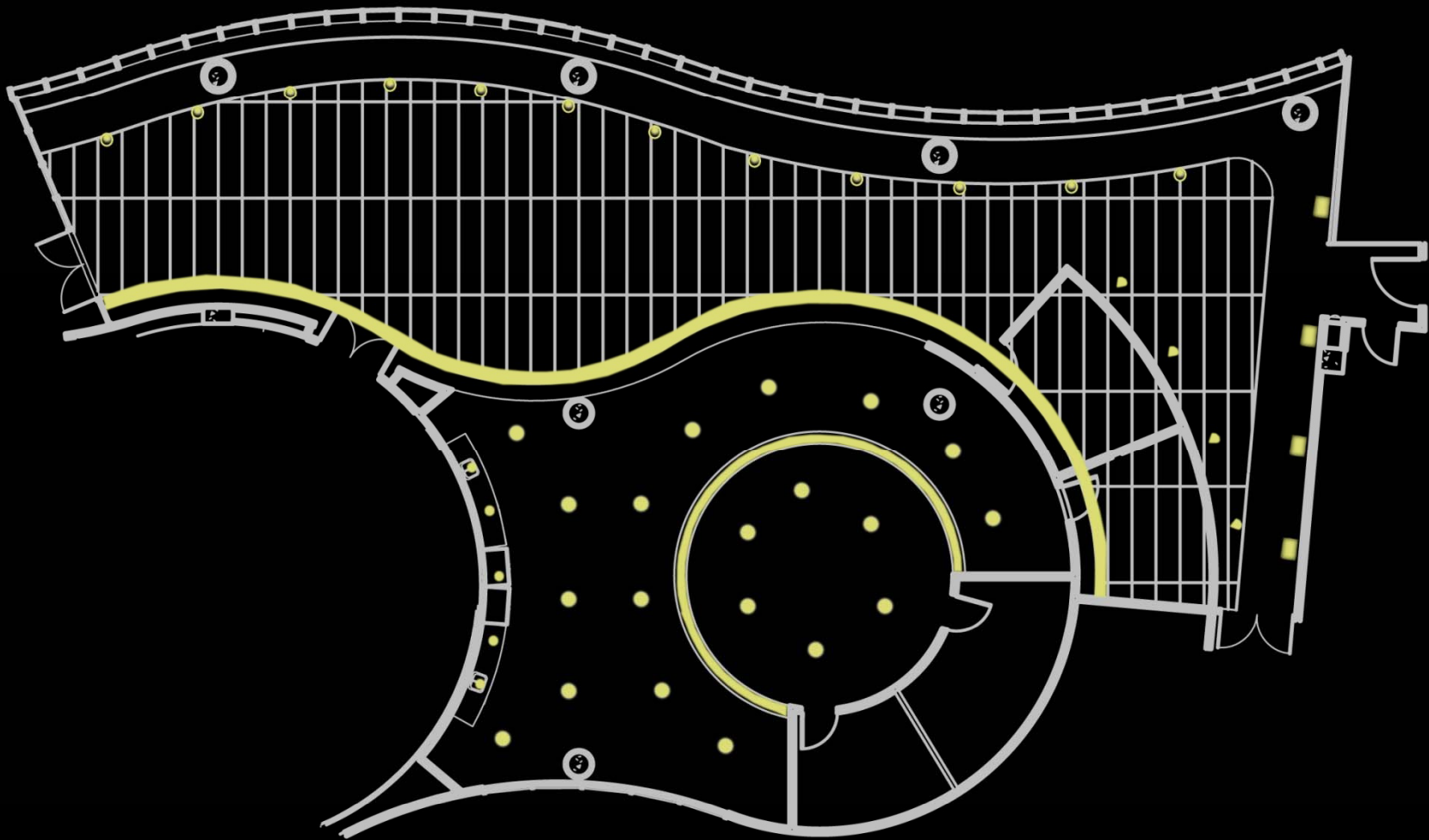

PT / OT | SCHEMATIC DESIGN

NATIONAL INTREPID
CENTER OF EXCELLENCE

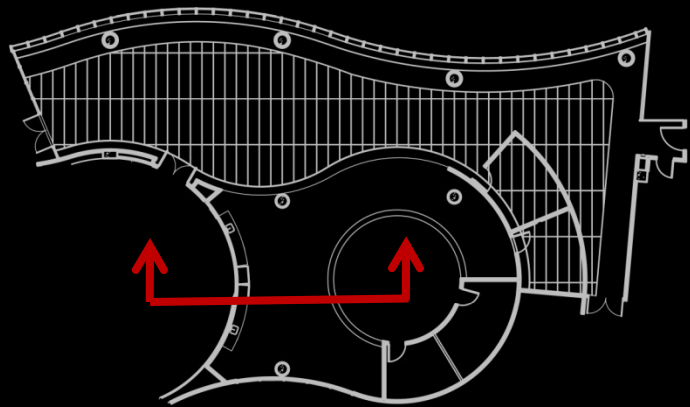

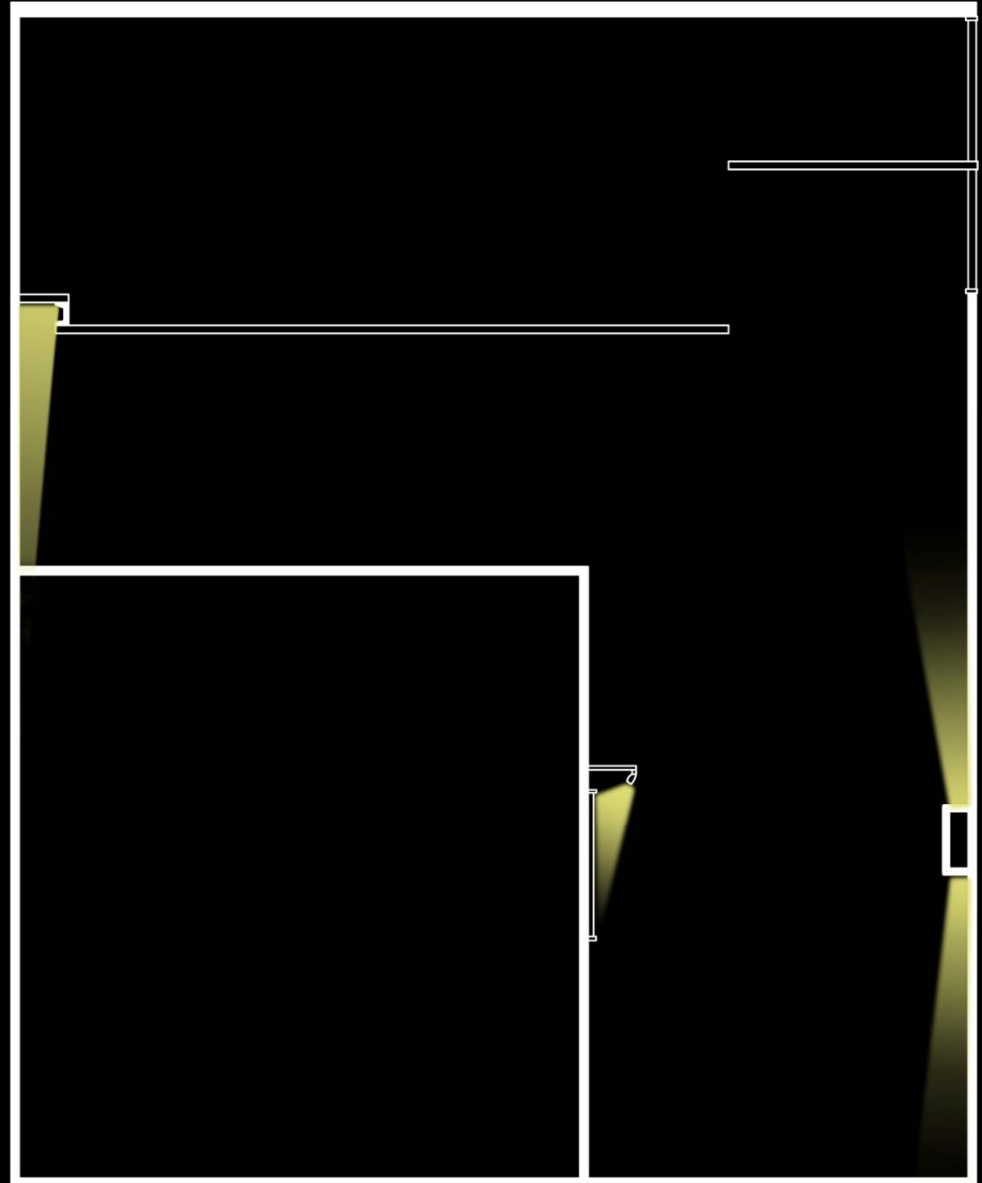
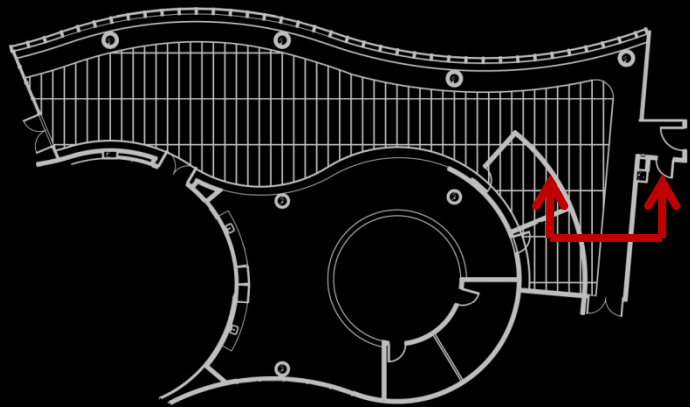

PT / OT | SCHEMATIC DESIGN

NATIONAL INTREPID
CENTER OF EXCELLENCE

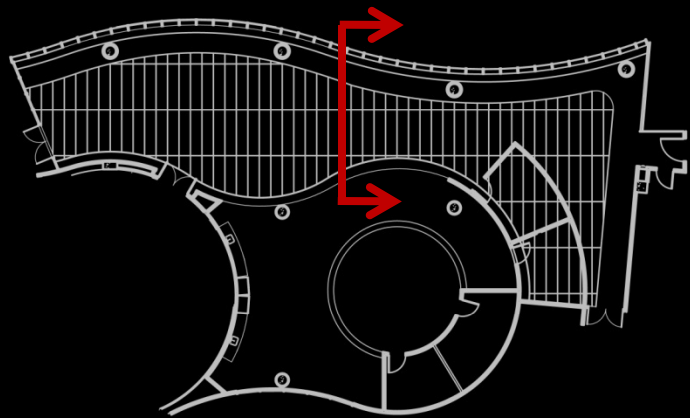
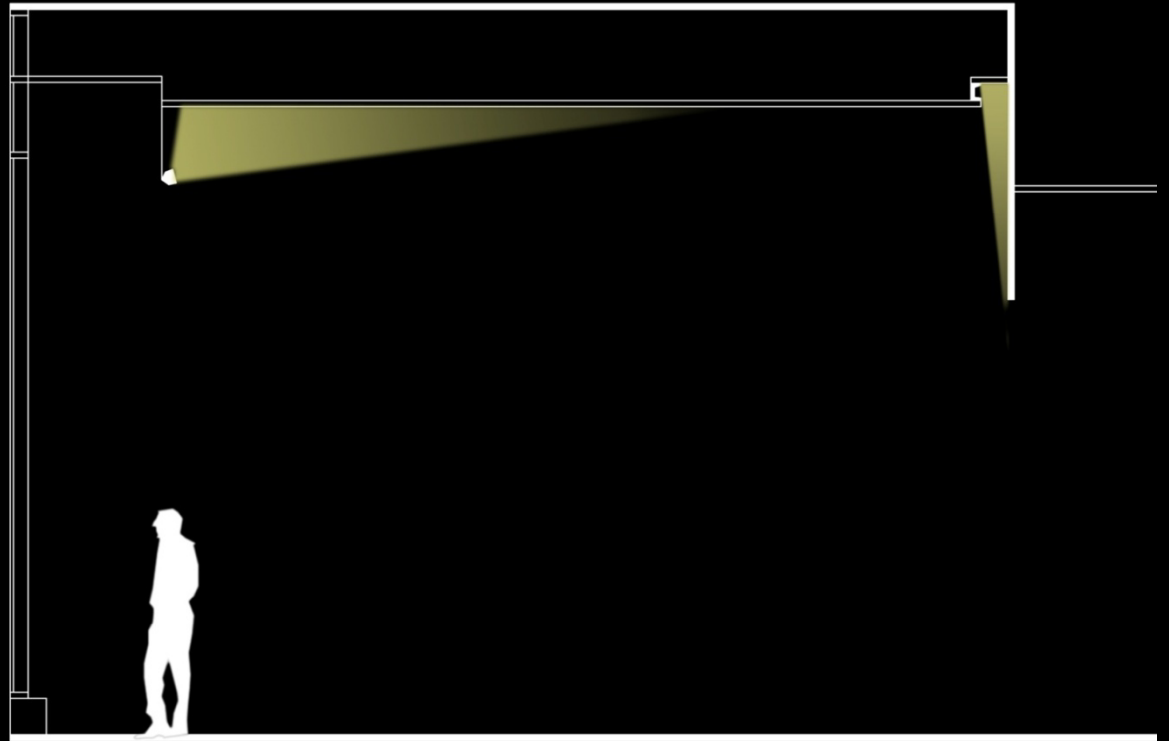



A horizontal band featuring a faded American flag with stars and stripes, serving as a background for the text.

QUESTIONS?
